



JOHN DEERE

4045TF258

POWERTECH

SPECIFICATIONS

For Gen Set Applications

TA LUFT approved @ 1500 rpm

EPA - CARB Tier 1 Certified @ 1800 rpm

Power Units

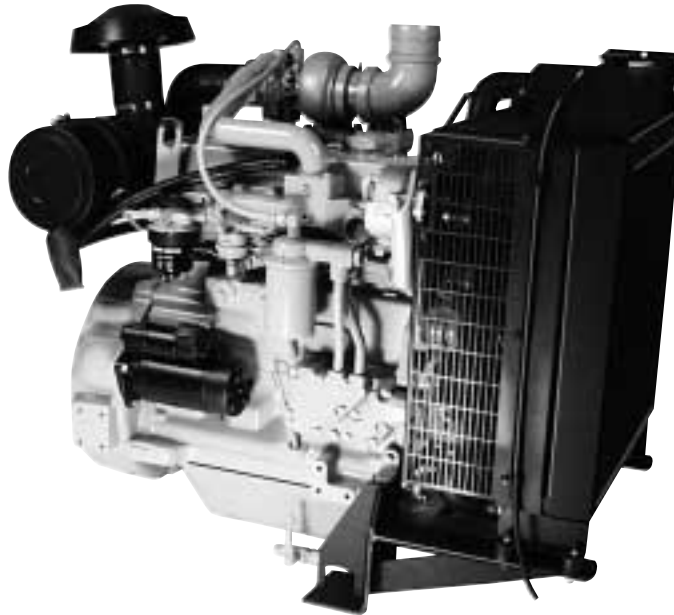

PERFORMANCE DATA

Speed (Hz)	Generator Efficiency %	Fan Power kW	Power Factor	Calculated Gen Set rating					
				Prime			Standby ⁽¹⁾		
				kW net	kVA	kWe	kW net	kVA	kWe
1500 (50)	88-92	3	0.8	72	79-83	63-67	80	88-92	70-74
1800 (60)	88-92	3.5	0.8	80	88-92	70-74	88	96-101	77-81

Note⁽¹⁾: based on nominal engine power

STANDBY POWER

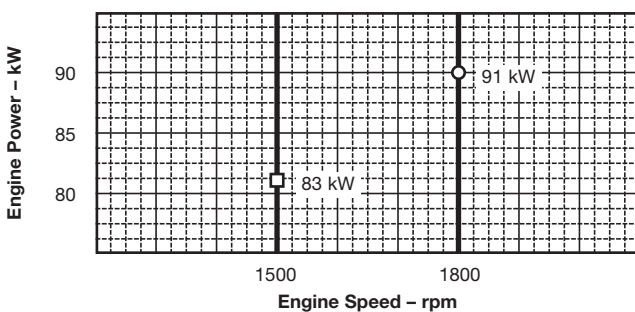

PRIME POWER

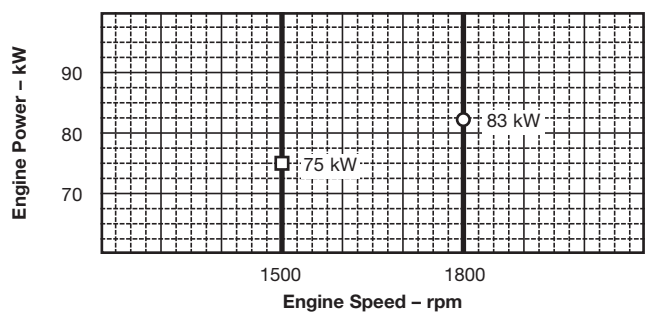

Performance Data

	1500 rpm	1800 rpm
Gross Rated Power (without fan)		
Prime = PRP - kW (hp)	75 (101)	83 (111)
Standby = LTP - kW (hp)	83 (111)	91 (122)
Rated Speed - rpm	1500	1800
Low Idle Speed - rpm	No	No
BMEP		
Prime = PRP - kPa (psi)	1333 (193)	1230 (178)
Standby = LTP - kPa (psi)	1476 (214)	1348 (195)
Friction Power @ Rated Speed - kW (hp)	10 (13)	13 (17)
Altitude Capability		
Prime - m (ft)	2300 (7500)	2900 (9500)
Standby - m (ft)	1500 (5000)	2100 (7000)
Air: Fuel Ratio		
Prime = PRP	26.0 : 1	30.7 : 1
Standby = LTP	25.2 : 1	30.9 : 1
Noise		
Prime = PRP - dB(A) @ 1 m	92.3	92.5
Standby = LTP - dB(A) @ 1 m	93.1	93.3

STANDBY POWER is the nominal engine power available at varying load factors for up to 500 hours per year. This rating conforms to ISO 8528-1 "limited time running power (LTP)". The calculated generator set rating range for standby applications is based on minimum engine power (nominal -5%) to provide 100% meet-or-exceed performance for assembled standby generator sets.

PRIME POWER is the nominal power an engine is capable of delivering with a variable load for an unlimited number of hours per year. This rating conforms to ISO 8528-1 "prime power (PRP)".

Photographs may show non standard equipment.



Power Unit Specification Data

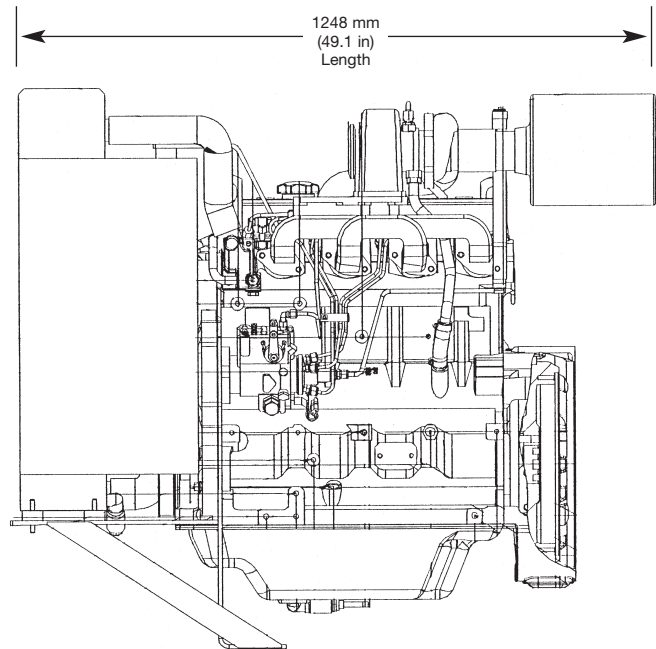
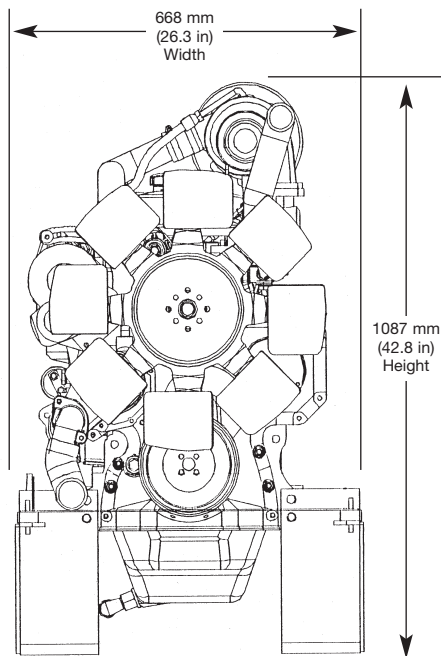

Fuel Consumption – l/h	1500 rpm		1800 rpm	
	Prime = PRP	Standby = LTP	Prime = PRP	Standby = LTP
25% Power	5.9	6.5	6.3	6.9
50% Power	11.9	13.1	11.4	12.6
75% Power	16.7	18.5	16.3	18.1
100% Power	23.3	25.7	21.5	23.7

General Data

Model	4045TF258
Number of cylinders	4
Bore and Stroke – mm (in.)	106 x 127 (4.19 x 5.00)
Displacement – dm ³ (in ³)	4.5 (276)
Compression Ratio	17.0 : 1
Valves per Cylinder – Intake/Exhaust	1 / 1
Firing Order	1-3-4-2
Combustion System	Direct Injection
Engine type	In-line, 4-cycle
Aspiration	Turbocharged
Engine Crankcase Vent System	Open
Engine Crankcase Pressure – kPa (in.H ₂ O)	0.5 (2)

Physical Data

Length – mm (in.)	1248 (49.1)
Width – mm (in.)	668 (26.3)
Height – mm (in.)	1087 (42.8)
Weight, dry – kg (lb)	548 (1208)
(Includes flywheel housing, flywheel, & electrics)	
Center of gravity location	
From Rear Face of block (X-axis) – mm (in.)	285 (11.2)
Right of Crankshaft (Y-axis) – mm (in.)	-10 (-0.4)
Above Crankshaft (Z-axis) – mm (in.)	151 (5.9)

Electrical Data

Recommended Battery Capacity (CCA)	
12 Volt System – Amp	640
24 Volt System – Amp	570
Maximum Allowable Starting Circuit Resistance	
12 Volt System – Ohm	0.0012
24 Volt System – Ohm	0.002
Starter Rolling Current – 12 Volt System	
At 0°C (32°F) – Amp	780
At -30°C (-22°F) – Amp	1000
Starter Rolling Current – 24 Volt System	
At 0°C (32°F) – Amp	600
At -30°C (-22°F) – Amp	700

Specifications and design subject to change without notice.

Air System

	1500 rpm	1800 rpm
Maximum Allowable Temperature Rise		
Ambient Air to Engine Inlet – °C (°F)	8 (15)	8 (15)
Maximum Air Intake Restriction		
Dirty Air Cleaner – kPa (in. H ₂ O)	6.25 (25)	6.25 (25)
Clean Air Cleaner – kPa (in. H ₂ O)	3 (12)	3 (12)
Engine Air Flow		
Prime = PRP – m ³ /min (ft ³ /min)	5.6 (198)	7.4 (261)
Standby = LTP – m ³ /min (ft ³ /min)	6.1 (215)	8.2 (290)

Exhaust System

	1500 rpm	1800 rpm
Exhaust Flow		
Prime = PRP – m ³ /min (ft ³ /min)	12.3 (434)	16.8 (593)
Standby = LTP – m ³ /min (ft ³ /min)	13.6 (480)	18.5 (653)
Exhaust Temperature		
Prime = PRP – °C (°F)	565 (1049)	530 (986)
Standby = LTP – °C (°F)	600 (1112)	560 (1040)
Max. Allow. Back Pressure – kPa (in.H ₂ O)	7.5 (30)	7.5 (30)
Recommended Exhaust Pipe Dia – mm (in.)	101.6 (4)	101.6 (4)

Cooling System

	1500 rpm	1800 rpm
Thermostat Start to open – °C (°F)	82 (180)	82 (180)
Power Unit Coolant Capacity – L (qt)	25.0 (26.5)	25.0 (26.5)
Minimum Air to Boil temperature – °C (°F)	47 (117)	47 (117)

Fuel System

	1500 rpm	1800 rpm
Fuel Injection Pump	Stanadyne	Stanadyne
Governor Regulation	5%	5%
Governor Type	Mechanical	Mechanical
Total Fuel Flow		
Prime = PRP – kg/h (lb/h)	93 (205)	96 (212)
Standby = LTP – kg/h (lb/h)	93 (205)	96 (212)
Maximum Fuel Transfer Pump Suction – m (ft)	0.9 (3)	0.9 (3)
Fuel Filter Micron Size @ 98% Efficiency	8	8

Lubrication System

	1500 rpm	1800 rpm
Oil Pressure at Rated Speed – kPa (psi)	345 (50)	345 (50)
Oil Pressure at Low Idle – kPa (psi)	105 (15)	105 (15)
In Pan Oil Temperature – °C (°F)	115 (240)	115 (240)
Total Engine Oil Capacity with filter – L (qt)	12 (12.7)	12 (12.7)
Engine Angularity Limits (continuous)		
Any Direction – degrees	20	20

This paper is environmentally friendly. (As it is not chlorine bleached)

1/02 7/5/5

YY12810.04E



John Deere Power Systems
La Foulonnerie
 Usine de Saran – B.P. 11013
 45401 Fleury les Aubrais Cedex – France

Tel.: (33) 2 38 82 61 19
 Fax: (33) 2 38 84 62 66
<http://www.johndeere.com/engines>

